

Display Pressure Transmitters



PTF30 Series PRODUCT MANUAL

For your safety, read and follow the considerations written in the instruction manual, other manuals and Autonics website.

The specifications, dimensions, etc. are subject to change without notice for product improvement. Some models may be discontinued without notice.

Features

- Minimized disturbance effect by improving noise resistance
- Excellent corrosion resistance with stainless steel housing
- High accuracy $\pm 0.2\%$ F.S.
- Various functions
 - User input range, display scale, output scale, digital filter, multi display selection, abnormal operation display, TUF (Two Unit Function), etc.
- Explosion-proof specification: Ex d IIC T6
- Protection structure: IP67 (IEC standard)
- Applications
 - Indoor heating, water supply and sewage, and incinerator and small and medium sized projects

Safety Considerations

- Observe all 'Safety Considerations' for safe and proper operation to avoid hazards.
- **⚠** symbol indicates caution due to special circumstances in which hazards may occur.

⚠ Warning Failure to follow instructions may result in serious injury or death.

- 01. Fail-safe device must be installed when using the unit with machinery that may cause serious injury or substantial economic loss. (e.g. nuclear power control, medical equipment, ships, vehicles, railways, aircraft, combustion apparatus, safety equipment, crime/disaster prevention devices, etc.)**
Failure to follow this instruction may result in personal injury, economic loss or fire.
- 02. Do not use the unit in the place where flammable/explosive/corrosive gas, high humidity, direct sunlight, radiant heat, vibration, impact or salinity may be present.**
Failure to follow this instruction may result in explosion or fire.
- 03. The explosion proof standard of this unit is Ex d IIC T6, protection structure of this unit is IP67 and the range of max. surface temperature is below 85°C.**
- 04. Do not disassemble or modify the unit.**
Failure to follow this instruction may result in fire or electric shock.

⚠ Caution Failure to follow instructions may result in injury or product damage.

- 01. Do not apply beyond rated pressure.**
Failure to follow this instruction may result in product damage.
- 02. Use the unit within the rated specifications.**
Failure to follow this instruction may result in fire or product damage.
- 03. Keep the product away from metal chip, dust, and wire residue which flow into the unit.**
Failure to follow this instruction may result in fire or product damage.
- 04. Check 'Connections' before wiring.**
Failure to follow this instruction may result in explosion or fire.
- 05. This product is designed to detect the pressure of noncorrosive medium. Do not use for corrosive medium.**
Failure to follow this instruction may result in product damage.
- 06. Use a dry cloth to clean the unit, and do not use water or organic solvent.**
Failure to follow this instruction may result in fire or electric shock.

Cautions during Use

- Follow instructions in 'Cautions during Use'. Otherwise, it may cause unexpected accidents.
- Power supply should be insulated and limited voltage/current or Class 2, SELV power supply device.
- The connection of this unit should be separated from the power line and high voltage line in order to prevent inductive noise.
- Do not use this unit near the high frequency instruments.
- Switch or circuit breaker should be installed nearby users for convenient control.
- Use verified explosion-proof cable gland or sealing fitting (explosion proof standard: over Ex d IIC T6, IP rating: over IP67 protection structure).
- Use dedicated external terminal for earth. For connecting earth, use a spring washer and earth cable which is over 4 mm².

- This unit may be used in the following environments.
 - Indoor / Outdoor (in the environment condition rated in 'Specifications')
 - Altitude max. 2,000 m
 - Pollution degree 2
 - Installation category II
- This explosion-proof unit is certified and the same specifications which is reported to Korea Gas Safety Corporation. (This unit is manufactured following by the announcement 2013-54 of Ministry of Employment and Labor of Korea.)**

Ordering Information

This is only for reference, the actual product does not support all combinations. For selecting the specified model, follow the Autonics website .

PTF30 - ① ② N ③ ④ - ⑤

① Pressure type

G: Gauge, sealed gauge ⁰¹⁾
A: Absolute pressure

② Rated pressure range

	Gauge	Absolute
1	0 to 35 kPa	0 to 35 kPa
2	0 to 0.1 MPa	0 to 0.1 MPa
3	0 to 0.2 MPa	0 to 0.2 MPa
4	0 to 0.7 MPa	0 to 0.7 MPa
5	0 to 2 MPa	0 to 2 MPa
6	0 to 3.5 MPa	0 to 3.5 MPa
7	0 to 7 MPa	
8	0 to 21 MPa	
9	0 to 35 MPa	
Sealed gauge		
A	-35 to 0 kPa	
C	-0.1 to 0 MPa	
F	-0.1 to 0.2 MPa	
H	-0.1 to 0.7 MPa	
M	-0.1 to 2 MPa	
O	-0.1 to 3.5 MPa	
Z	Custom	

- 01) The pressure is sealed gauge pressure. The unit is sealed structure. It is based on atmospheric pressure 101.3 kPa (1.013 bar).
02) The pressure range is set to customized pressure range. (select "Z" at ② Rated pressure range)

③ Install bracket

N: Without bracket
B: With bracket

④ Pressure port

F8: G3/8 (PF)

⑤ User pressure range ⁰²⁾

Customized pressure range and unit

Product Components

- Product
- Instruction manual

Specifications

Series	PTF30
Applicable medium	Gas, liquid, oil (except corrosive environment of SUS316)
Power supply	15 - 35 VDC≐
Output	DC 4 - 20 mA (2-wire, impedance: ≤ 30 Ω, low limit: 3.6 mA (- 2.5 %), high limit: 21.6 mA (+ 10 %)
Accuracy ⁰¹⁾	± 0.2 % of F.S. (at 25 °C)
Temperature characteristic	± (0.075 % × URL + 0.15 % × Span) (at 20 °C)
Sampling period	300 ms
Setting method	Front key
Display type	12 segment LCD, 4 digit
Certification	CE, ENEC, ETL
Unit weight	≈ 1.2 kg

01) F.S. is rated pressure range.

Insulation Resistance	≥ 100 M.Ω (500 VDC≐ megger)
Dielectric strength	Between the charging part and the case: 1,000 VAC~ for 1 min
Vibration	0.75 mm amplitude at frequency of 5 to 55 Hz in each X, Y, Z direction for 2 hours
Noise immunity	Square shaped noise by noise simulator (pulse width 1 μs) ± 240 V
Memory retention	≈ 10 years (non-volatile semiconductor memory type)
Ambient temperature	-20 to 70 °C, storage: -20 to 80 °C (rated at no freezing or condensation)
Ambient humidity	0 to 85 %RH (rated at no freezing or condensation)
Protection structure	IP67 (IEC standard)
Material	Body: aluminum (AlDc.8S), cover O - Ring: Buna N, diaphragm: SUS316, connection: SUS316
Explosion class ⁰¹⁾	Ex d IIC T6

01) This explosion class is acquired and managed by Konics Co., Ltd.

Dimensions

- Unit: mm, For the detailed drawings, follow the Autonics website.

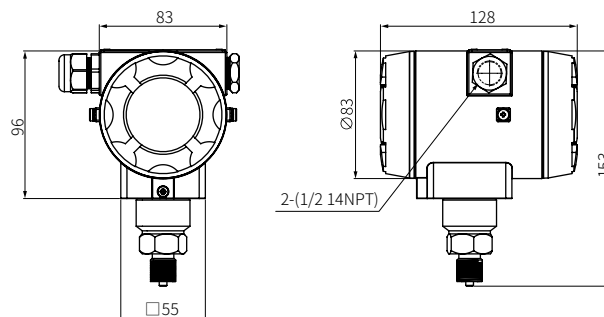

■ With bracket

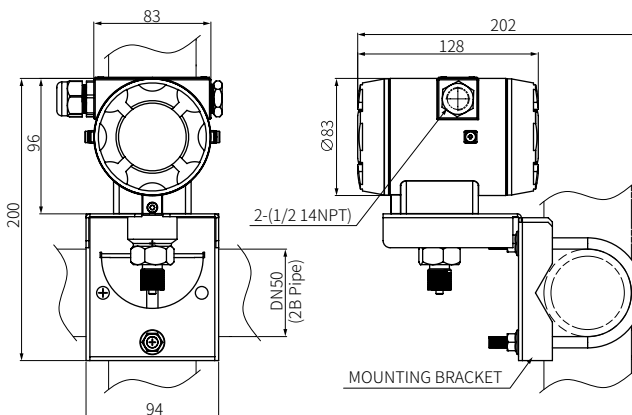

Connections

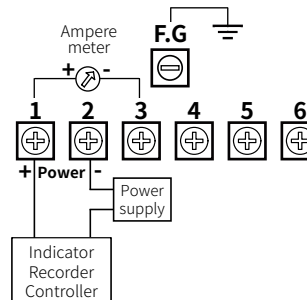

Unit Descriptions

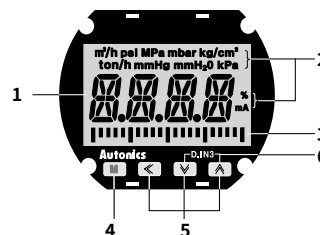

- 1. Display part**
Displays PV (present value), SV (Setting value) and error discription.
- 2. Unit display part**
Displays the currently set input unit.
- 3. Output scale bar graph**
Displays output DC 4 - 20 mA as scale bar graph by 5% unit.
- 4. [M] key**
Used to enter parameter mode, move parameters and save SV.
- 5. [◀], [▼], [▲] key**
Used to enter parameter set mode, move digits.
- 6. D.IN3**
Press [▼] + [▲] keys at the same time for 3 sec to executes digital input function. (parameter)

Mode Setting

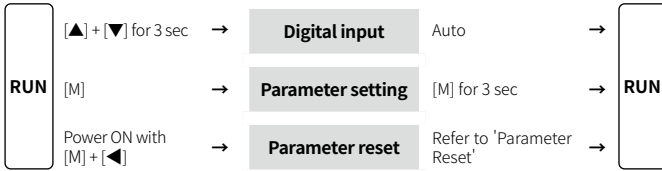

Parameter setting

- Some parameters are activated/deactivated depending on the model or setting of other parameters.
- After entering setting group, press the [M] key for 3 sec or there is no additional key input in 30 sec, it returns to RUN mode.
- [M] key: saves setting value and moves to the next parameter.
- [◀] key: moves digit
- [▼], [▲] key: changes setting value,

Parameter	Display	Default	Setting range	Condition
1-1 Pressure unit	UNI t	bRR	bar, mbar, Pa, kPa, MPa, G.CM (gf/cm ²), KG.CM (kgf/cm ²), M.M.H2 (mmH ₂ O), psi, mmHg, %, OFF	-
1-2 Input value low limit	L - RB	0.000	Within rated pressure range	-
1-3 Input value high limit	H - RB	0.350		
1-4 Decimal point	dP	0.000	0.0, 0.00, 0.000, 0	-
1-5 Display scale low limit	L - SC	0.000	-1999 to 9999	1-1 Pressure unit: %, OFF
1-6 Display scale high limit	H - SC	1000		
1-7 Zero-point adjustment	ZER o	000	-999 to 999	-
1-8 Slope correction	SPRN	1.000	0.900 to 1.100	-
1-9 Output scale low limit	L o Ut	0.000	Within rated pressure range or within 1-5 / 6 display scale low / high limit*	* 1-1 Pressure unit: %, OFF
1-10 Output scale high limit	H o Ut	0.350		
1-11 Moving average digital filter	MAR F	04	01 (OFF) to 16	-
1-12 Digital input	dI - K	H o L d	HOLD: hold display value, Z-TM: remote zero ⁰¹⁾	-
1-13 RUN mode display value 1	dSP 1	PV	PV: present value, OUT: output,	-
1-14 RUN mode display value 2	dSP 2	PV	L,PEK: min. value ⁰²⁾ , H,PEK: max. value ⁰²⁾	-
1-15 Dual unit	tUF	oFF	[Sealed gauge model] OFF, ON	-
1-16 Lock	L o C K	oFF	OFF: enable to check / set, LOC.1: enable to check / disable to set, LOC.2: disable to check / set	-

01) It is possible to check and change correction value in 1-7 zero-point adjustment.

02) When selecting L,PEK / H,PEK, left / right side of output scale bar graph flashes for 0.5sec.

When the min. / max. value is out of the temperature range, it displays LLLL / HHHH and it can be initialized to PV by pressing [▲] + [▼] keys for 3 sec.

Parameter Reset

Resets all parameters as factory default.

- While holding down the [M] + [◀] keys, turn ON the power of the device.
- When 'CLR' appears in display part, press [M] key to parameter reset mode.
- When 'NO' appears in display part, change the text to 'YES' by pressing [▲], [▼] key in display part and press [M] key to finish the reset process.

Errors

Display	Operation	Troubleshooting
HHHH	Flashes when measured pressure is higher than the input value high limit.	Adjust measured pressure within the input value high / low limit.
LLLL	Flashes when measured pressure is higher than the input value low limit.	
ERR	Flashes when there in an error to SV.	Check the setting values and reset.

Digital input

Remote zero

Executes zero-point adjustment function when external input signal is applied.

Hold

Holds current display value and control output when external input signal is applied.

Input: ———— Display: ————

- When not using hold function

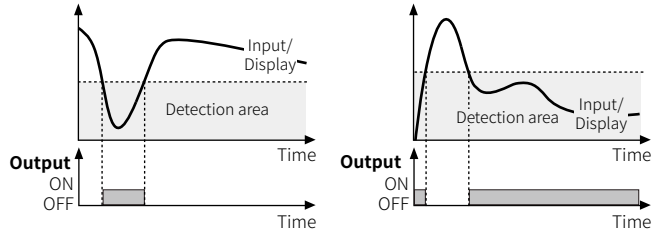

- When using hold function

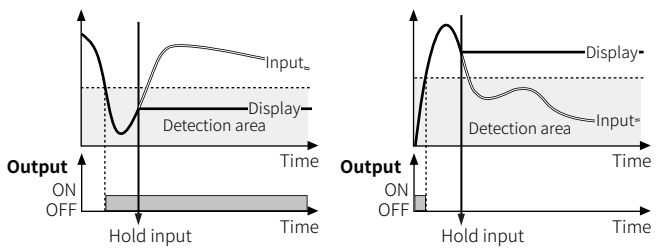

Functions

Zero-point adjustment

The current pressure value on display is set to zero forcibly by removing deviations from the open pressure port. Zero-point adjustment affects analog output.

- For precise measurement, execute zero-point adjustment periodically.

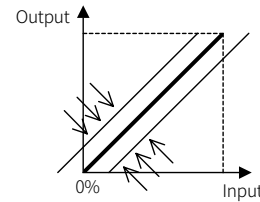

Measurement range

Sets the output range between maximum and minimum input.

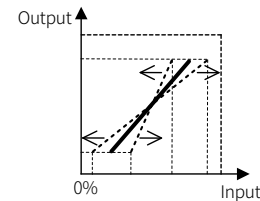

Display / Output scale

Customizes the scale of display / output value from rated output range. If the measured input is a, b, and the arbitrary values to be displayed are A, B, the display / output value are outputted for input a and b linearly (a = A, b = B).

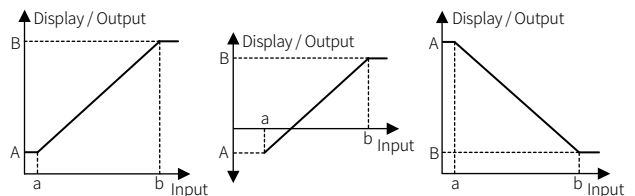

Hold input

Corrects the output error in the maximum input state.

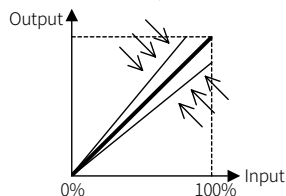

■ Max./Min. value monitoring

In order to identify abnormal conditions of the system or diagnose the max. / min. input, the product saves the values and notifies to the user when they are out of range.

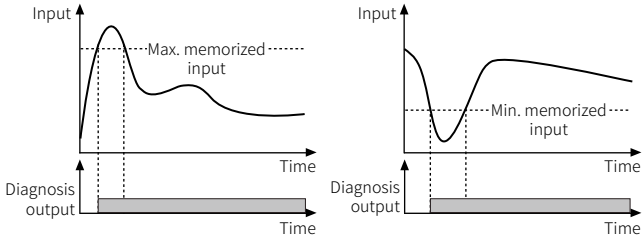

■ Dual unit

For sealed gauge pressure model, this function displays the input pressure which is below atmospheric pressure by mmHg unit. It displays the input pressure atmospheric pressure or over by the set pressure unit.

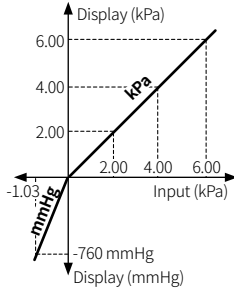

Pressure Conversion Table

	Pa	kgf/cm ²	mmHg	mmH ₂ O	psi	bar	inHg
Pa	1	0.000010197	0.007501	0.101972	0.00014504	0.00001	0.0002953
kgf/cm ²	98066.5	1	735.5592	10000.0005	14.223393	0.980665	28.959025
mmHg	133.3224	0.001359	1	13.595099	0.019337	0.001333	0.039370
mmH ₂ O	9.80665	0.000099	0.073556	1	0.00142	0.000098	0.002896
psi	6894.733	0.070307	51.71475	703.016716	1	0.068947	2.036014
bar	100000.0	1.019716	750.062	10197.1626	14.503824	1	29.529988
inHg	3386.388	0.034532	25.40022	345.315507	0.491156	0.033864	1

• 1,000,000 Pa = 1,000 kPa = 1 MPa

Segment Table

The segments displayed on the product indicate the following meanings. It may differ depending on the product.

7 segment	11 segment	12 segment	16 segment
0 0 i l	0 0 i l	0 0 i l	0 0 i l
1 1 j J	1 1 j J	1 1 j J	1 1 j J
2 2 k K	2 2 k K	2 2 k K	2 2 k K
3 3 L L	3 3 L L	3 3 L L	3 3 L L
4 4 m M	4 4 m M	4 4 m M	4 4 m M
5 5 n N	5 5 n N	5 5 n N	5 5 n N
6 6 o O	6 6 o O	6 6 o O	6 6 o O
7 7 P P	7 7 P P	7 7 P P	7 7 P P
8 8 q Q	8 8 q Q	8 8 q Q	8 8 q Q
9 9 r R	9 9 r R	9 9 r R	9 9 r R
A A S S	A A S S	A A S S	A A S S
b B t T	b B t T	b B t T	b B t T
c C u U	c C u U	c C u U	c C u U
d D v V	d D v V	d D v V	d D v V
E E w W	E E w W	E E w W	E E w W
F F x X	F F x X	F F x X	F F x X
G G y Y	G G y Y	G G y Y	G G y Y
H H z Z	H H z Z	H H z Z	H H z Z